

# Anschluß / Wiring BAUR pdc285 ← → Incremental Encoder Motor sm2x-xP2200-000

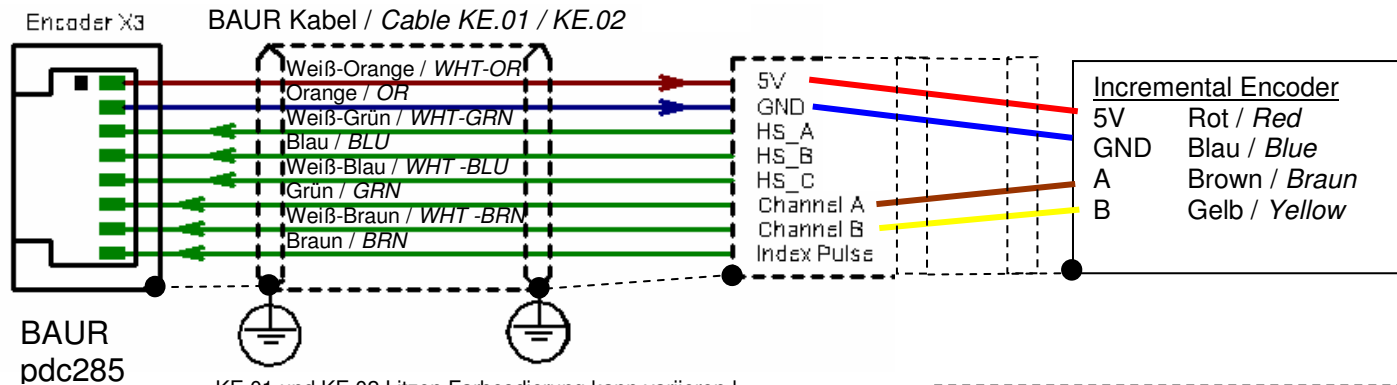

KE.01 und KE.02 Litzen Farbcodierung kann variieren!  
 Bitte Kabel individuell auf Durchgang prüfen.  
*KE.01 and KE.02 cable lead colors may vary.  
 Please check cable connectivity individually.*

## 2 Phase(n) Stepper Motor Phase A und/and Phase B

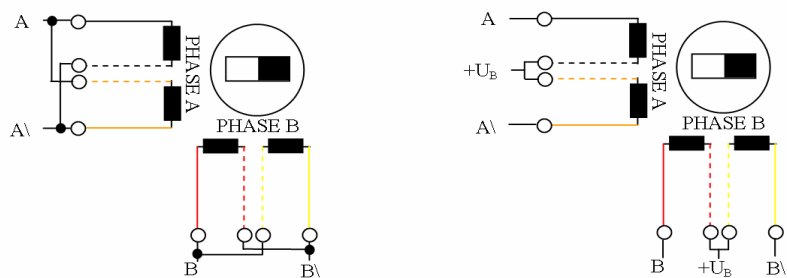

BIPOLAR PARALLEL

BIPOLAR SERIAL / UNIPOLAR

PHASE A:	schwarz(black)	PHASE B:	rot(red)
	schwarz(black)/weiss(white)		rot(red)/weiss(white)
	orange(orange)/weiss(white)		gelb(yellow)/weiss(white)
PHASE A':	orange(orange)	PHASE B':	gelb(yellow)

**Wichtiger Hinweis: Alle Schirmungen/Erdungen niederohmig und sternförmig auflegen!**  
*Important Notice: Connect Shielding /Grounding with low impedance to common ground point!*

**Wichtiger Hinweis: Auf ausreichende Kabelzugentlastung und saubere Kabelführung achten!**  
*Important Notice: Sufficient cable strain relief and cable support is absolutely necessary!*