

Operator Manual

2-Phase-Stepper Drive smd266 and smd298

3- Phase-Stepper Drive smd366 and smd398



Revision: 13/2008 subject to change without prior notice

Product Features

- for all common 2-phase and 3 Phase stepper motors
- smdx66 primarily for 60mm (NEMA23) motor sizes
smdx98 primarily for 90mm (NEMA34) motor sizes
- powerful drive: bipolar chopper, low noise and losses
- only one power supply necessary

smdx66: from 24 Volt to 60 Volt
smdx98: from 24 Volt to 90[130] Volt

- current setting with HEX-switch

smdx66: (1,5 to 6)A
smdx98: (2 to 8)A

- steps per revolution:
200, 400, 500, 1000, 2000, 2500, 5000 and 10000
- automatic current reduction can be enabled
- robust screw terminal connectors

- Dimensions:

H:W:D smdx66: 130x29(44 with HS)x80(mm)
smdx98: 157x29(44 with HS)x80(mm)

HS= Heat Sink

- Inputs(optically isolated): Pulse, Direction, OFF
- Outputs (optically isolated): Ready
- step frequency up to 150 kHz
- LED-indicators for status and diagnostics
- ballast resistor at over-voltage

Options:

- Open frame, wall mount, heat sink

Set-up Elements smdx66

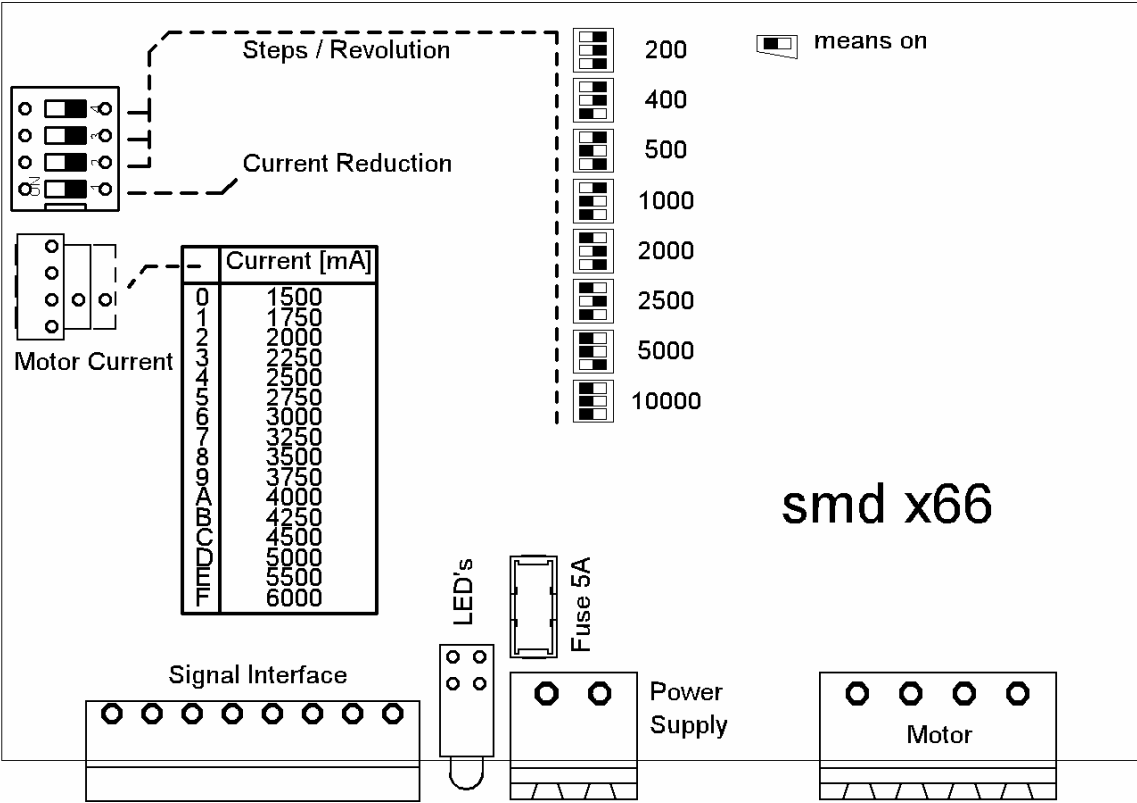

Set-up Elements smdx98

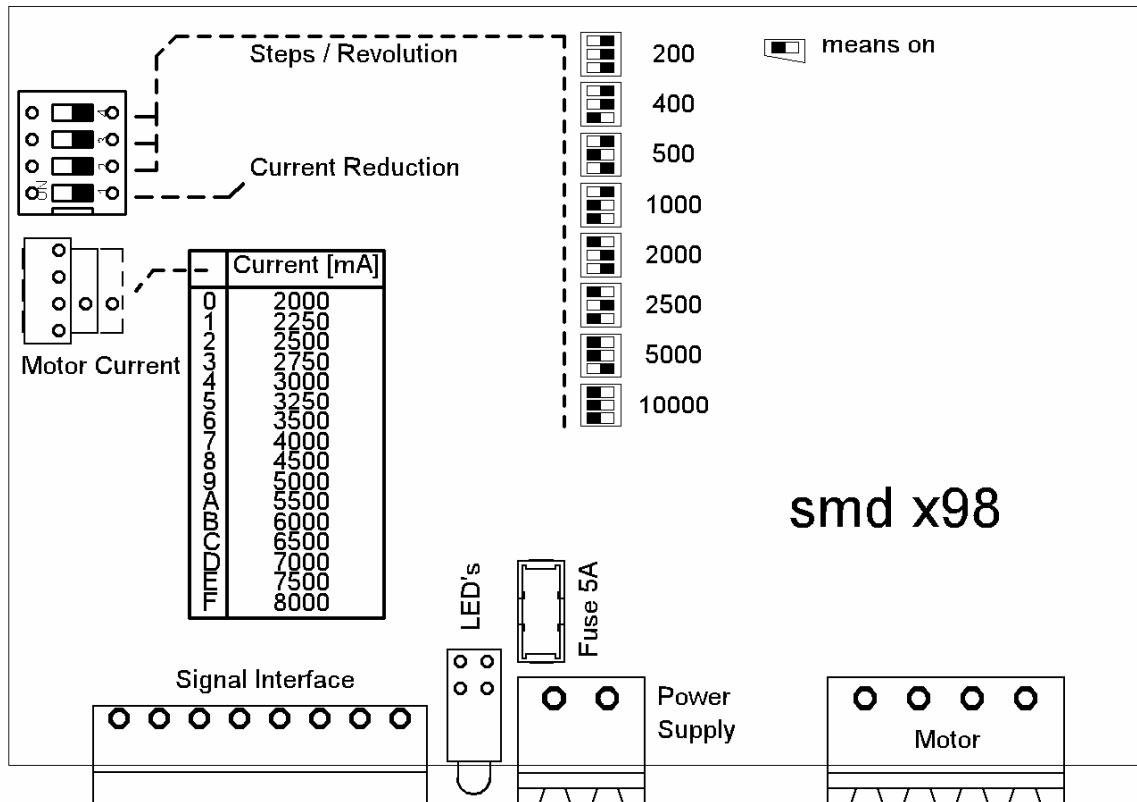

Wiring Diagram for smd266 and smd298

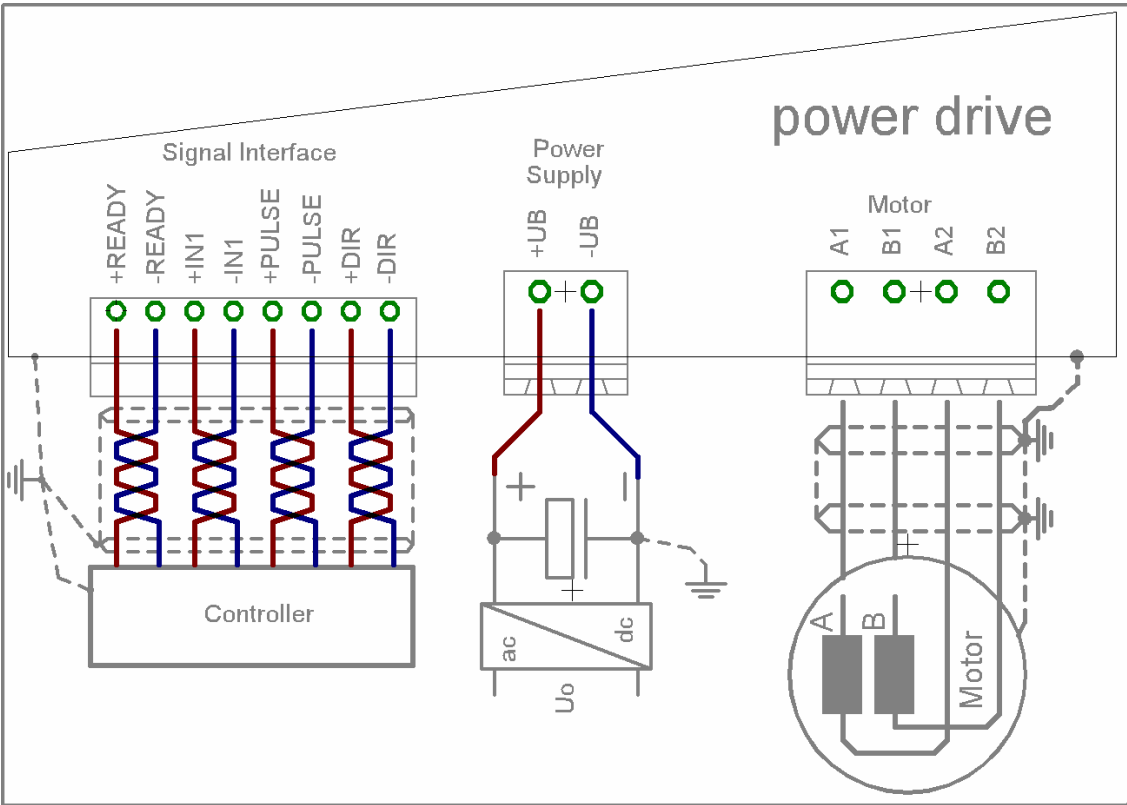

Wiring Diagram for smd366 and smd398

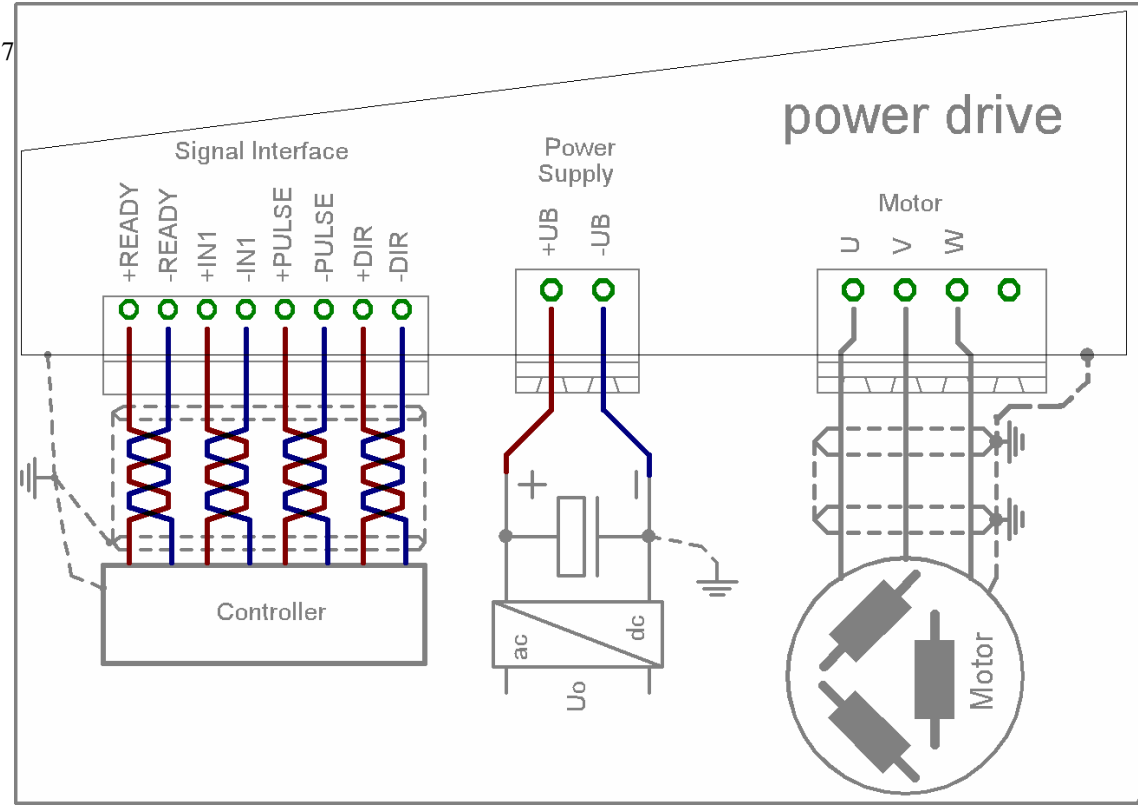

Signal Description:

Pulse, Dir and **IN1** are wide range inputs and can be operated with 3.5...24V signal voltage.

PULSE: (Pulse)

A step is executed with each positive signal edge. The power drive exclusively reacts on signal edges. In case of an active current reduction (switch „current reduction“ on) and pulse pauses greater than approx. 1s, the motor current is reduced to approx. 60% of the set value.

DIR: (Direction)

The direction signal defines the sense of motor rotation. The logic assignment can be inverted by swapping the wires of one motor phase.

e.g. Phase A1 and A2 at smd266 and smd298 or
Phase U and Phase V at smd366 and smd398.

IN1: (OFF standard)

Input IN1 is an auxiliary input that can be defined for different tasks. Per default the function of the input is "OFF". The motor is switched off by activating the input "OFF". The current chopper is switched off. This feature is occasionally used in measuring equipment to be able to measure even the smallest signal amplitudes without interference. This condition allows to move the motor mechanically.

READY: (READY)

This output is switched on when the drive is functional. In an error state the contact is opened, the condition is indicated with LED L1.

Status display with L1 and L2

Ready: L1 on
L2 on in Zero-Position

Error: L1 off, L2 flashes (see below):
2x Low-voltage occurred
3x Over-temperature
4x Over-current detected

The error state can be reset with input IN1.

POWER SUPPLY: (+Ub, -Ub)

The drive can be operated in the range of
24 to max. 60 Volt (smdx66) and
24 to max. 90[130] Volt (smdx98)

It must be guaranteed that the power supply voltage at no load and +10% mains over-voltage does not exceed 60 Volt (at smdx66) and 90[130] Volt (at smdx98) and that there is a sufficient charge capacitor of at least 6800µF.

Never connect live supply voltage wires to the terminals, because the sudden charge current of the internal electrolytic capacitors can destroy the internal fuses

! CHECK FOR CORRECT POLARITY

MOTOR CONNECTION smd266 and smd298:

By swapping a phase, e.g. phase A1 and A2 the motor sense of rotation can be inverted to the logic assignment of the direction signal „DIR“.

MOTOR CONNECTION smd366 and smd398:

By swapping a phase, e.g. phase U and V the motor sense of rotation can be inverted to the logic assignment of the direction signal „DIR“.

Under no circumstances motor wires must be disconnected during operation. Induction voltages can destroy the power drive. For this reason assure proper contact of the motor wires at the screw terminal.

Signal Interface

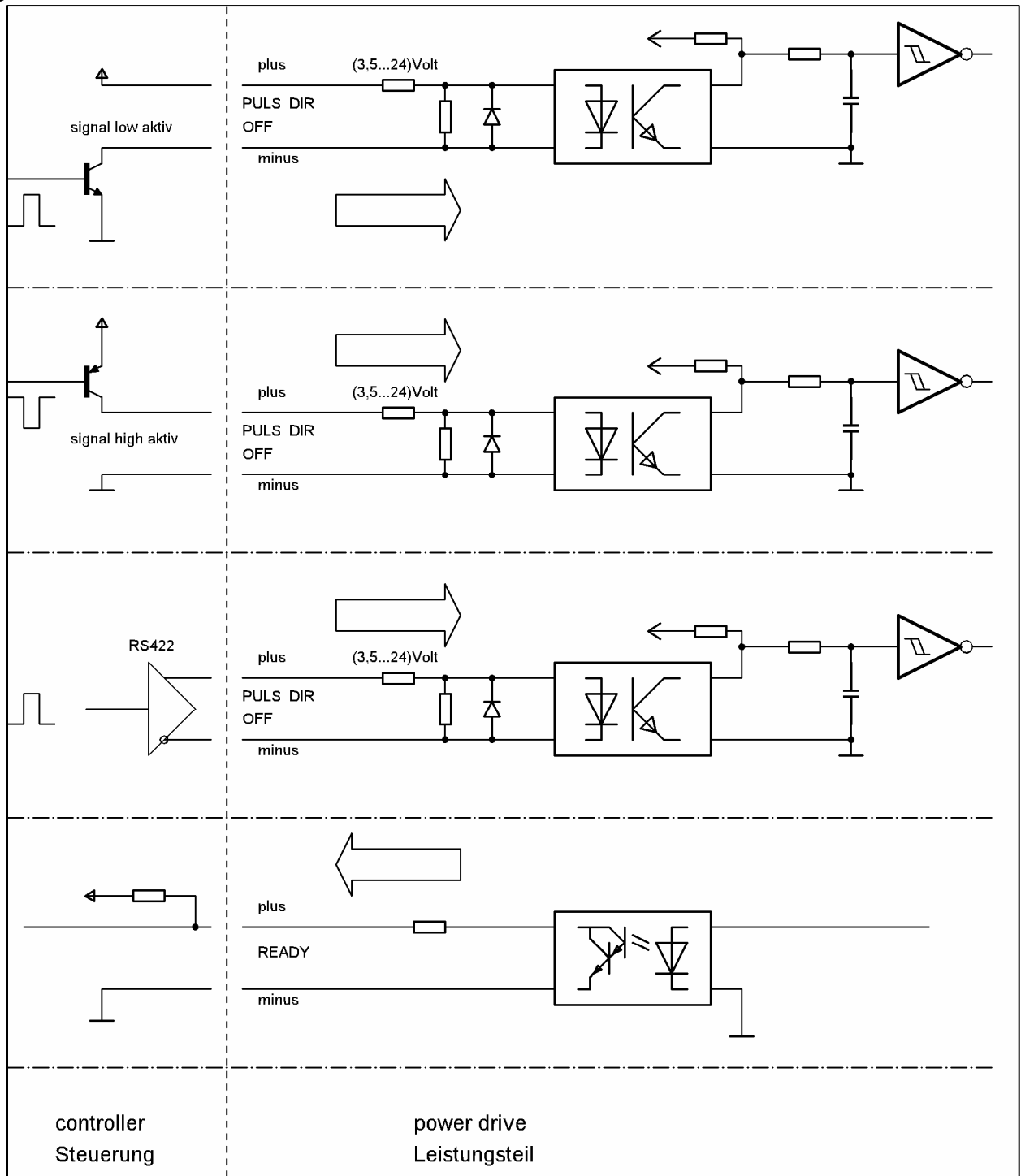

The signal interface is completely isolated by opto-isolators. To have a wide flexibility, both inputs plus and minus of the opto-isolators are available. So its easy to drive the signal interface with high-, low- or RS422 active signals.

All signals have a wide range voltage input and can be operated with signal voltage levels between 3.5V to 24V .

Signal Timing

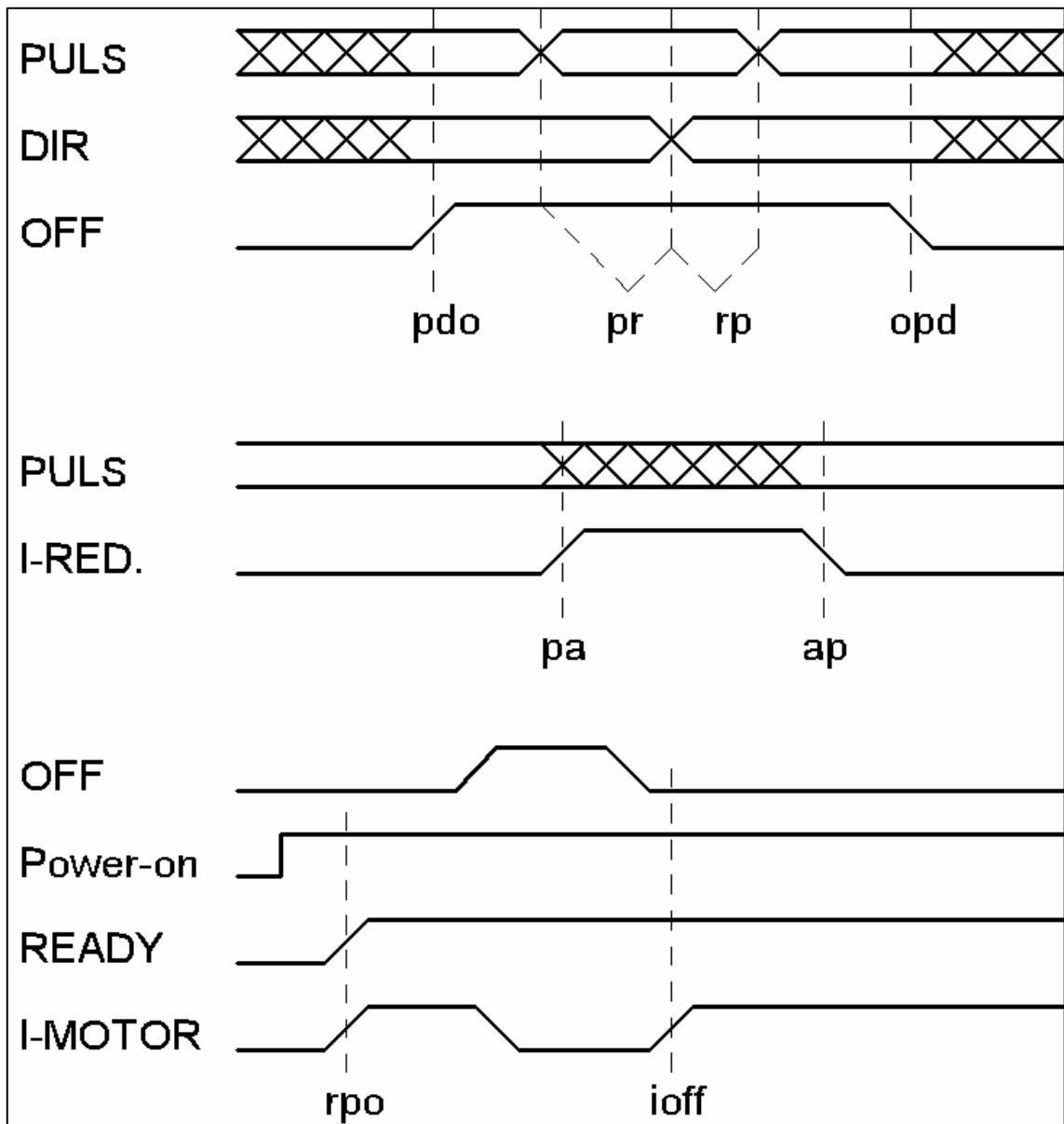

! Pulse slope: <math>< 2\mu\text{s}</math>
! Pulse width: $> 5\mu\text{s}$

| | | |
|-------|-------------------------------|--|
| pdo: | > 5 μs | OFF active after PULSE, DIR |
| opd: | > 10ms | PULSE, DIR active after OFF |
| pr: | > 5 μs | PULSE before DIR |
| rp: | > 5 μs | PULSE after DIR |
| pa: | 1s | Current Reduction active after PULSE |
| ap: | <math>< 500\mu\text{s}</math> | Current Reduction deactivate after PULSE |
| rpo: | < 1s | READY after power on |
| ioff: | < 10ms | motor current after OFF |

STEP RESOLUTION: (steps per revolution)

Select the steps/revolution with the DIP-switch.

! Only when power drive is off

Using a standard hybrid stepper motor with 50 magnetic poles result in following steps/revolution:
200, 400, 500, 1000, 2000, 2500, 5000 and 10000

Running performance:

☹ less than 400 ☹ 400 ☺ more than 400

The step performance improves with higher motor current (set nominal motor current)

Behavior of resonance

The motor resonance can be reduced by increasing the steps/revolution. Following table will show the effect under the condition the resonance at full step will be 100%

| steps/rev.: | behavior of resonance |
|-------------|-----------------------|
| 200 | 100% |
| 400 | 29% |
| 800 | 8% |

MOTOR CURRENT SETTING: (motor current)

The motor current is set precisely with the HEX switch.
In general only as much current should be set as actually is required for the application. (see also "Operating Elements" on page 4).

At higher pulse rates the motor current reduces because of the motor inductance. (see diagrams from manufactures).
In this case a high current motor with low inductance is recommended.

Automatic current reduction is recommended.**CURRENT REDUCTION: (current reduction)**

"Current Reduction" activates the automatic current reduction. The motor current is reduced to approximately 60% of the set motor current. The losses in the motor as well as in the drive can therefore be significantly reduced.

! Current reduction reduces holding torque. Assure the resulting holding torque is acceptable for your application.

The current reduction is activated, if the pulse input is inactive for more then approx. 1s.

At pulse frequencies less than 1 Hz it can happen that the current reduction is briefly switched on. To avoid this effect the start/stop-frequency should be set significantly than 1 Hz. Immediately after detecting an active pulse input nominal current is restored.

It is recommended to generally activate the current reduction. Practical experience values show that the temperature can be reduced more than 10°C

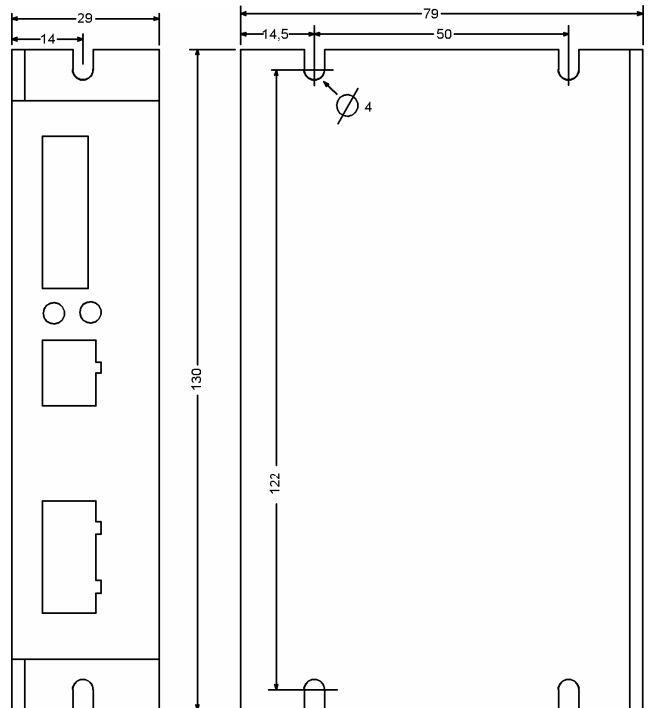
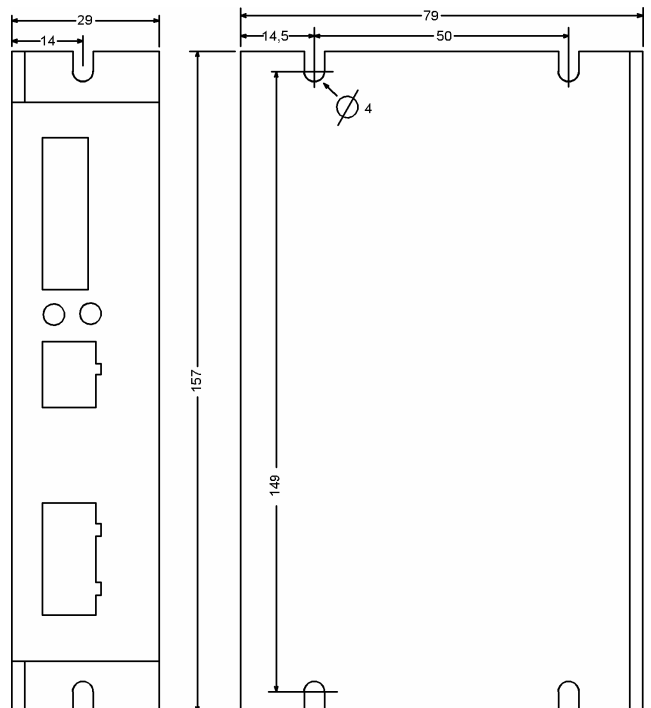
Dimensions smdx66**Dimensions smdx98**

SPECIFICATIONS:**Power drive supply:**

| | |
|-------------------------------------|---------------------|
| Absolute max. voltage: | |
| smdx66: | 60Vmax. |
| smdx98: | 90[130]Vmax. |
| Minimum voltage: | 21V |
| Recommended voltage | |
| smdx66: | 24..58 V |
| smdx98: | 24..80 V |
| Voltage ripple: | < 2.0V peak |
| Input peak current at power on: | < 2.0A peak |
| Fusing: | |
| smdx66: | 3,0 A medium |
| smdx98: | 5,0 A medium |
| Power supply charge capacitor: | >6800µF |
| Power supply cable cross section: | 0,75mm ² |
| Distance to power supply capacitor: | < 1m |

Motor connection:

| | |
|----------------------|----------------------|
| Cable cross section: | >0,75mm ² |
| Cable length: | <10m |

Signal input interface: (wide range 3.5V to 24V)

| | | | |
|----------------|--|---------|--|
| Input type: | opto coupler, reverse polarity protected | | |
| Input voltage: | low: | <1V | |
| | high: | >3.5V | |
| | nominal: | >4.5V | |
| | max: | <28V | |
| Input current: | | < 16 mA | |
| Pulse width: | | > 5µs | |
| Pulse slope: | | < 2µs | |

Ready:

| | | | |
|--------------------|--------------|--------------|--|
| Output type: | opto coupler | | |
| Switching voltage: | min. | 3 V | |
| | max. | 30 V | |
| Switching current: | | < 50 mA | |
| Impeadance: | | <20 Ohm | |
| Load: | | non-reactive | |

Motor current setting:

| | |
|------------------------------|----------|
| smdx66: Hex-Switch, 16 steps | 1,5...6A |
| smdx98: Hex-Switch, 16 steps | 2,0...8A |

smdx66 ambient conditions: (for $U_b < 50V$)

| | | |
|--------------|------------------|---------|
| Temperature: | $I_{Motor} 1,5A$ | 50° max |
| | $I_{Motor} 2,5A$ | 45° max |
| | $I_{Motor} 6,0A$ | 30° max |

smdx98 ambient conditions: (for $U_b \leq 80V$)

| | | |
|--------------|----------------|---------|
| Temperature: | $I_{Motor} 2A$ | 50° max |
| | $I_{Motor} 4A$ | 45° max |
| | $I_{Motor} 8A$ | 30° max |

Heat sink: recommended for motor phase current settings higher than 5A

UL94V-1 all components
IP20

TROUBLE SHOOTING:**Motor has no holding torque but supply voltage is connected**

- The motor voltage is below the minimum value
- Signal inputs "Off" is active

Motor has holding torque, but doesn't execute steps

- The pulse signal level is too low

Sudden "crackling" noises in the motor

- Motor is operated at the minimum voltage limit
- The motor connection is bad

The motor doesn't reach the set speed but starts

- The motor voltage is too low for the required speed
- The motor current was set too low
- The acceleration ramp was set too high
- Motor wires are too long or too small cross section
- Power supply is not powerful enough

The motor "loses" steps and drifts

- The amplitudes of the control signals are too low
- Signal cable noise is too high (shielded cables?)
- The wiring concept is not optimal (all ground signals must be connected one common potential)
- The mechanical shaft coupling has play
- The motor stalls and can't follow

Motor vibrates at pulse frequency and doesn't start

- Start/Stop-frequency too high
- Motor windings are connected wrong or broken cable
- The automatic current reduction remains active (pulse duration too low at low pulse frequencies)
- The motor current is set too low

The automatic current reduction doesn't work

- The pulse input remains active after the last
- The current reduction is not enabled

The motor is hot

Up to 85 ° Celsius should be no problem

The power drive ICs are hot

Up to 85 ° Celsius should be no problem

Poor step accuracy

- Motor inductance is too high
- Motor current setting is too low

GENERAL INSTALLATION REQUIREMENTS

The device housing¹ must be grounded separately. In most cases a wing nut on the front panel or another grounding connection is available. Each component must be grounded with a separate grounding wire at a central "grounding point". This is usually the machine bed or a grounding rail inside the electrical cabinet.

Before installation and setup make sure that the required drive power is sufficient for your application and that the maximum values are not exceeded.

Mounting orientation is vertical, make sure air intake¹ and cooling slots are not blocked.

Only shielded motor cable must be installed. For identical potential between motor flange and power drive (short distance) the shield is grounded on both ends. Otherwise it is recommended to ground only the device end and that the shield on the motor end is ground connected galvanically isolated via a capacitor.

In general the ground potential difference must be in the range of only a couple mV.

For symmetrical motor cables such as with 2 phase steppers twisted pair wires are recommended per circuit.

Signal cables must also be shielded. Twisted pair wires are recommended per circuit.

The ground potential common point should be located directly at the housing or the mounting point of the power drive.

Signal cable and motor cable must be separated. Long parallel cable installation must be avoided. Cable crossings (if necessary) should be installed vertically.

Check all device settings for validity.

SAFETY AND PROTECTION REQUIREMENTS

The installation of the device must only be conducted by an educated, trained and experienced expert (electro). The local guidelines for safety, installation of electrical and mechanical systems and EMI must be observed.

Unintended operation and faulty installation of the device can lead to personal injury (incl. the possibility of death) and the device as well as other external components can be damaged or an excessive pollution of the environment can occur.

Operation is only permitted with the mounted housing². Because of eventually present high voltage the device must not be opened (also not after a long period of idle time). Make sure children have no direct access to the device.

No technical modifications of the device are permitted.

The device housing³ must be grounded separately. In most cases a wing nut on the front panel or another grounding connection is available. The device must be grounded prior to the installation.

Under no circumstances live of functional connectors must be removed or connected. All installations must be conducted in the powerless de-energized state.

Device operation in damp, humid environment or with present spray water is not permitted.

¹ if available

² not with open frame (only PCBs)

³ if available

Notes: