

*Operator Manual
for
2(3)-Phase Stepper Motor Drive
smd x85*



Heatsink optional

Product features

For all common 2-phase and 3 Phase stepper motors, primarily for 60mm (Nema 23) and .90mm (Nema34) motor sizes

2 Phase Steppers:

8-wire technology, windings switched parallel or in series

3 Phase Steppers:

3-wire technology, windings switched in delta configuration

Powerful drive: bipolar chopper, low noise and losses

Only one power supply necessary

Motor current adjustment with HEX-switch

Steps/revolution:

2-Phase : 200, 400, 800, 1600, 500, 1000

3-Phase : 400, 500, 1000, 2000

Optimized torque ripple between steps

Step frequency up to 150 kHz

Switchable automatic current reduction

LED-indicators for supply voltage, over current, over temperature, over voltage(ballast), and zero phase

Protected against over temperature, excessively high motor current and power supply voltage surges (integrated active ballast circuit)

Inputs: PULSE, DIRECTION, GATE, OFF, RESET, FAST (Opto coupler)

Outputs: READY, ZEROPHASE(Reference point) (Opto coupler)

Compact housing, metal

Ordering Number Key

smdx85.xxxx0xx

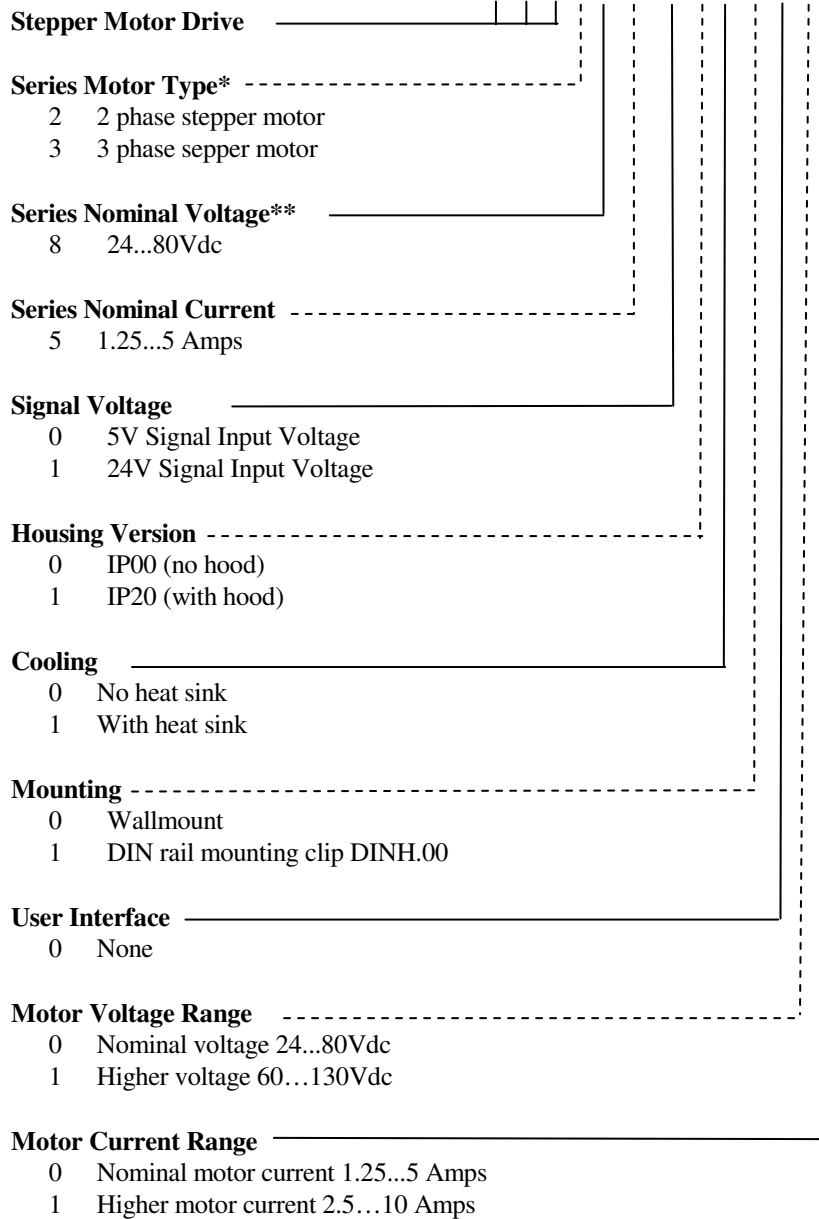

Accessories (separate order items)

STS.01	Connector set for: supply voltage, motor und signals
HS.00	Heatsink (recommended for phase currents above 6A)
DINH.00	DIN-rail mounting clip
KM <i>m</i>	Motor cable 2x2 0.75mm ² twisted pairs with overall shielding <i>m</i> = Length in Meter 01, 02, 05, 10 (e.g.: 2 Meter motor cable = KM02)
DOKU	DIN-A5 paper bound operator manual

* 2 phase or 3 phase stepper motors upon request. We can assist with motor sizing and drive calculation.

** PFC power supply ps400 (400 Watt 80Vdc or 130Vdc) upon request

Placement of the operating elements

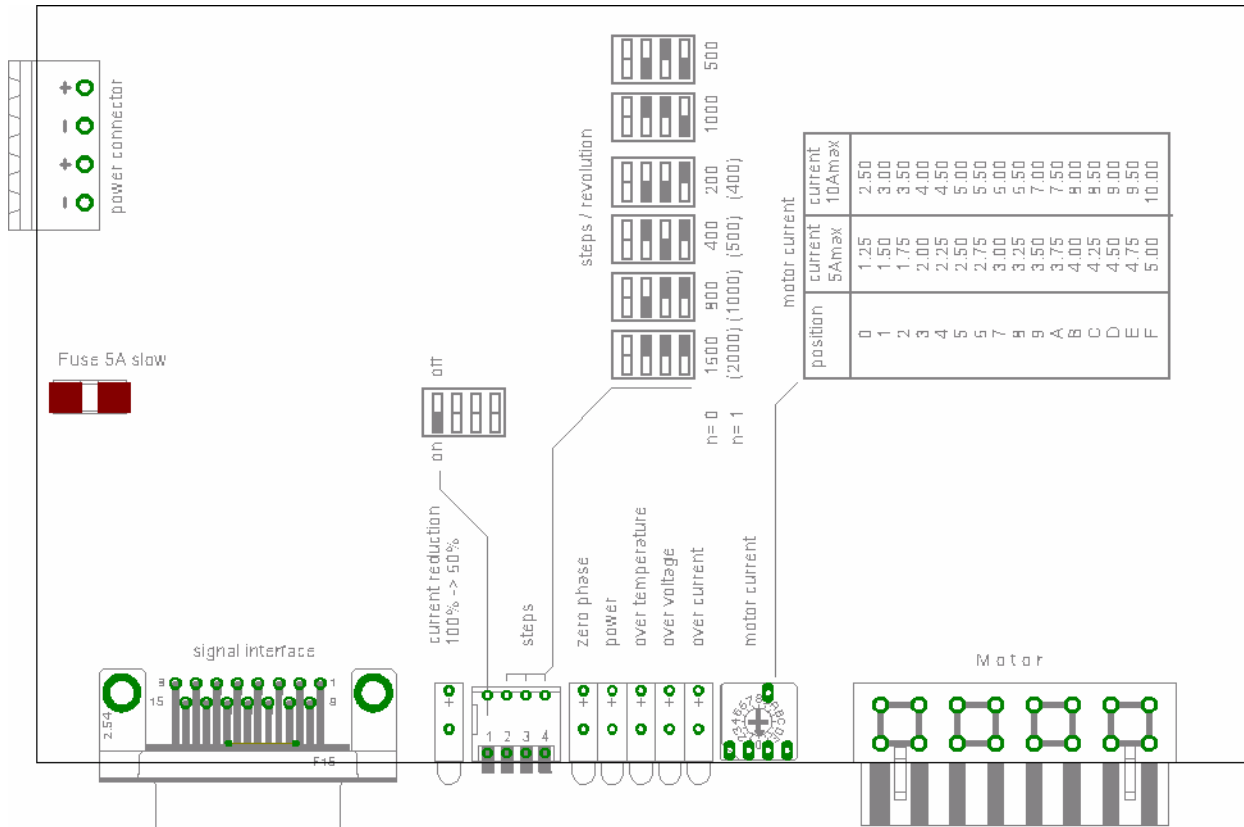

Wiring Diagram 2 Phase Stepper

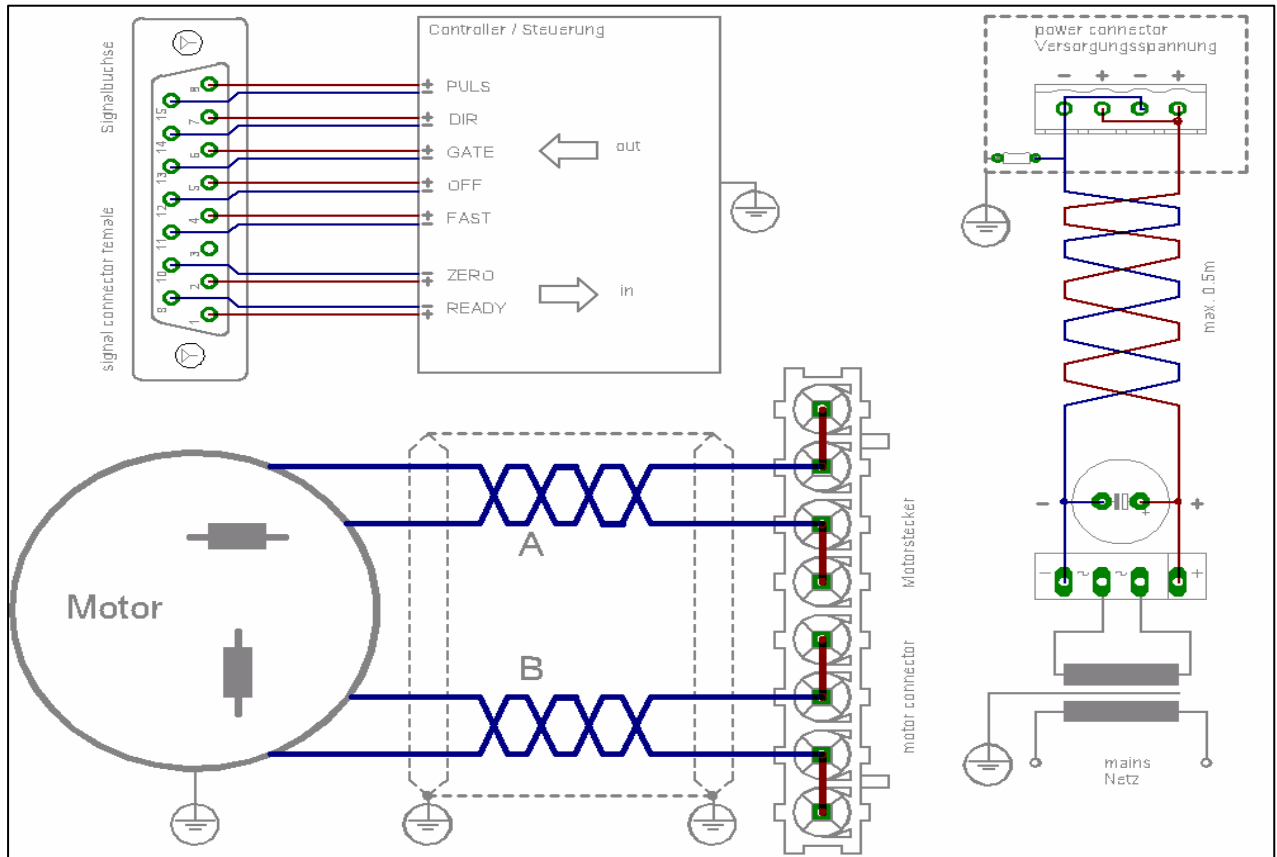

Wiring Diagram 3 Phase Stepper

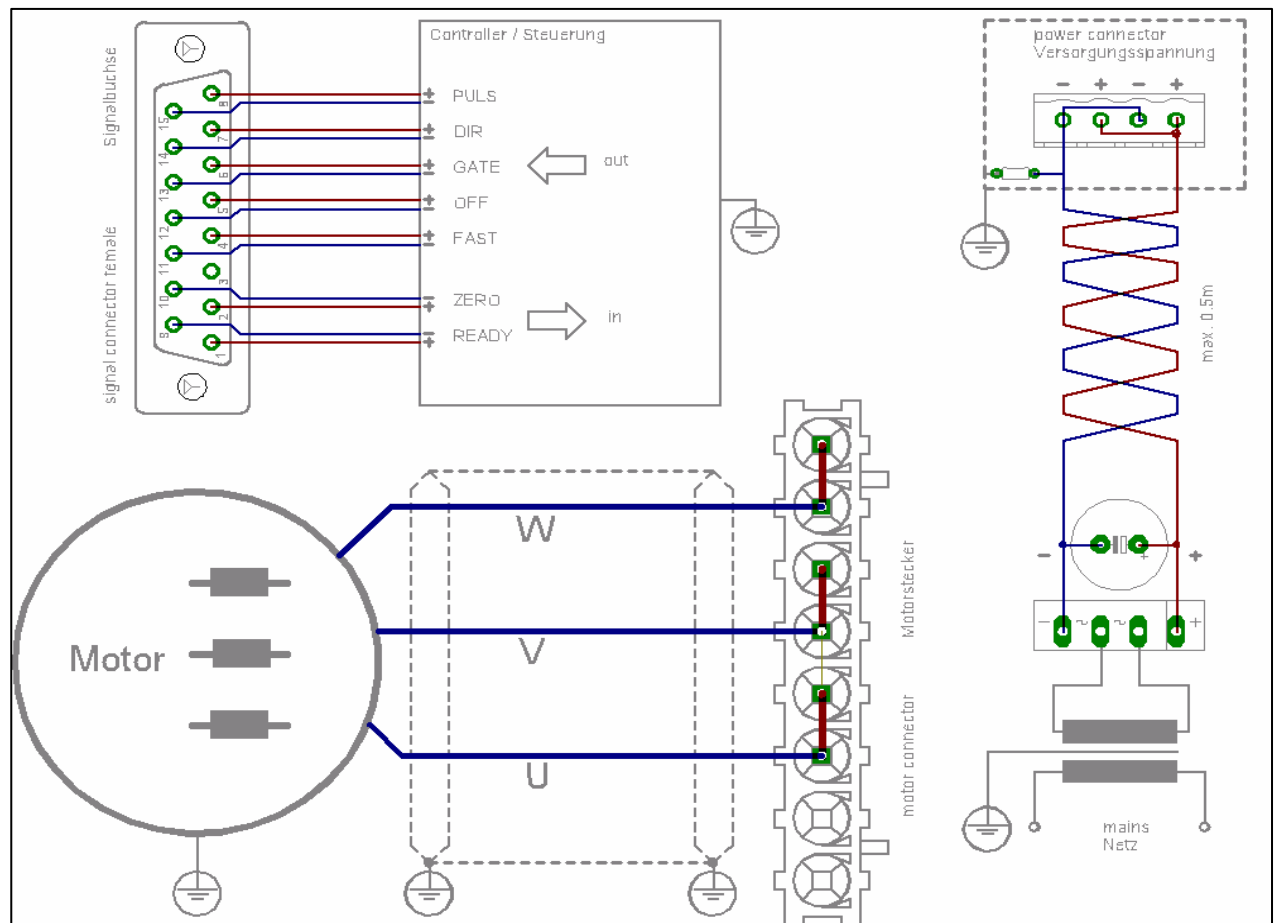

Signal description

PULS:

A step is executed with each positive signal edge. The power drive exclusively reacts on signal edges. In case of an active current reduction (switch „current reduction“ on) and pulse pauses greater than approx. 100ms, the motor current is reduced to approx. 60% of the set value.

The current reduction is not active if the pulse signal stays on active.

DIR: (Direction)

The direction signal defines the sense of motor rotation. The logic assignment can be inverted by swapping the wires of one motor phase.

GATE:

The power drive ignore all input pulses if the input GATE is activated. With this function it is possible to operate multiple power drives from one pulse source.

OFF/RESET:

When active, the motor current is switched to zero. The motor shaft can now easily be rotated manually.

OFF/RESET:

Change from error condition to operating condition. Independent of the current motor position, the motor switches to ZERO position.

While the RESET signal is active, the motor current is switched to zero and the motor is without torque.

READY:

This output is switched when the drive is functional. The following faults switch the output to high impedance: low voltage, over current/temperature. This condition is hold until „RESET-Signal“ is active or the power drive is switched off and on again. The power drive senses READY approx. 200ms after power supply is stable.

ZEROPHASE: (Reference point)

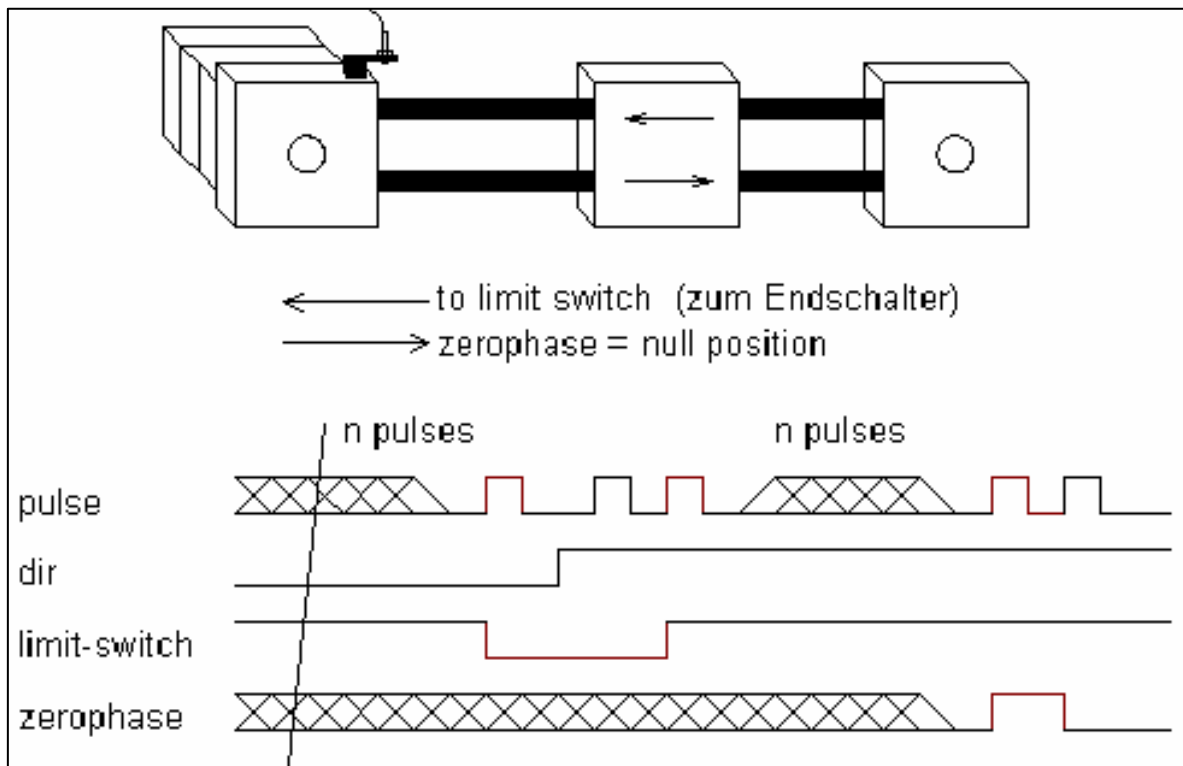

ZERO phase or ZERO position can be used as an exact reference point. Following is a procedure to handle with ZERO points.

First move carefully to the limit switch, reverse the direction and move until ZERO phase is active. Be sure, the ZERO phase don't coincides with the limit switch hysteresis and perhaps adjust the limit switch position.

Depending on the pulses/revolution the ZERO phase becomes active after n pulses under the condition the direction doesn't change

steps/rev.:	ZEROPHASE after n pulses
200	4
400	8
800	16
1600	32
500	10
1000	20

FAST:

Activating of this input switches to the halve resolution. So the result is the double motor speed.

! It acts only at the 1600, 1000 and 400 steps/revolution.
 ! Switching only at even positions 2,4,6,...

2 Phase Stepper Motor connections:

The motor connector is optimized to drive stepping motors with 4 wires. Having 8 wires, connect 2 windings for each phase in parallel mode. This results in well dynamics at higher frequencies.

By swapping the wiring connection of one motor phase, e.g. phase A, the motor sense of rotation can be inverted to the logic assignment of the direction signal.

3 Phase Stepper Motor connections:

In regular, the motor is driven in triangle mode. This results in well dynamics at higher frequencies.

By swapping the wiring connection of two phases, e.g. phase U and V, the motor sense of rotation can be inverted to the logic assignment of the direction signal.

Under no circumstances motor wires must be disconnected during operation. Induction voltages can destroy the power drive. For this reason assure proper contact of the motor wires at the socket.

Interface:

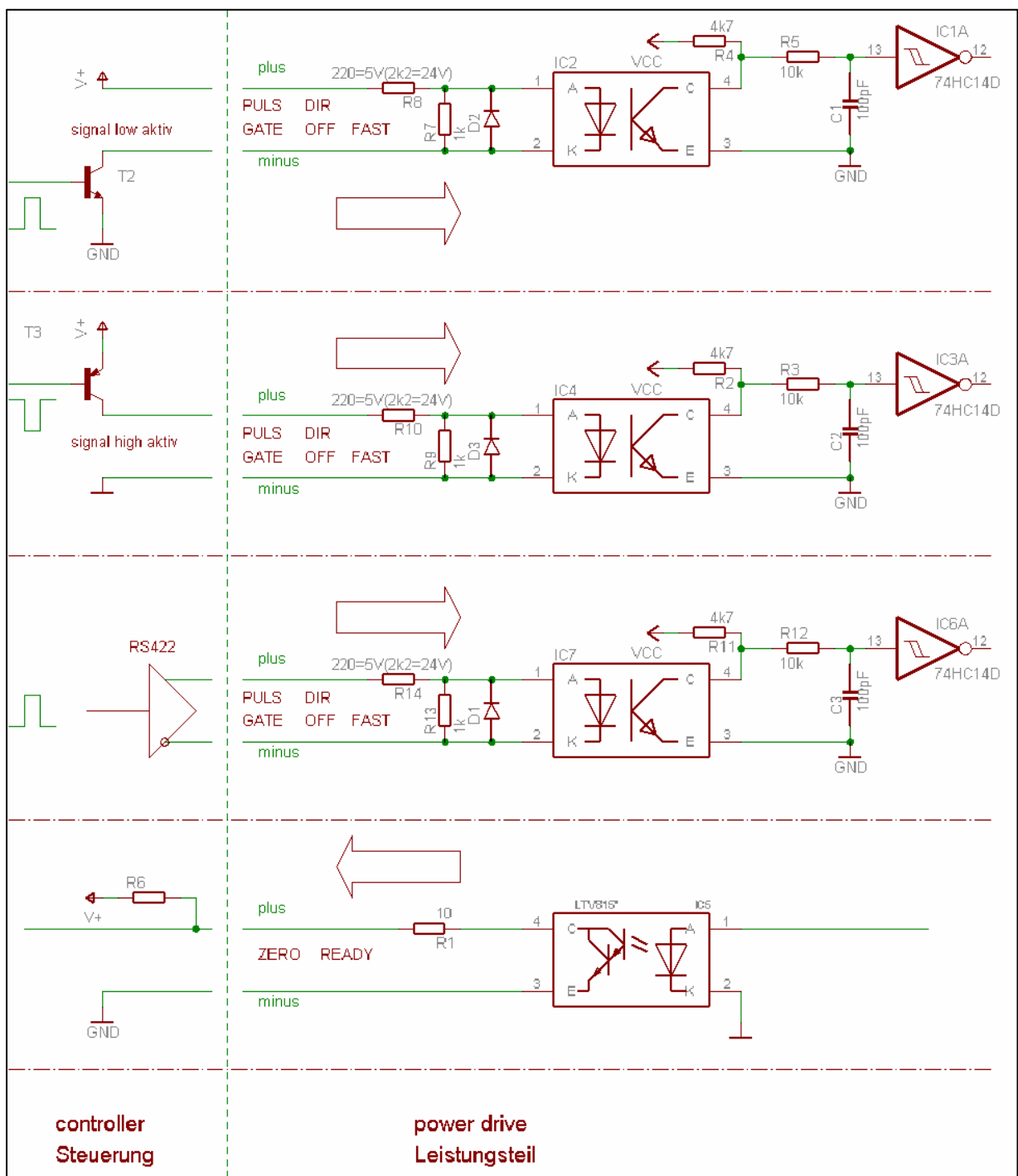

The signal interface is completely isolated by opto couplers. To have a wide flexibility, both inputs plus and minus of the opto couplers are available. So its easy to drive the signal interface with high-, low- or RS422 active signals.

Never operate a power drive prepared for 5V-signals with 24V signals, the opto couplers will be damaged

Steps per revolution

Select the steps/revolution with the DIP-switch.

! Only when power drive is off

Using a standard hybrid stepper motor with 50 magnetic poles result in following steps/revolution:

2-Phase : 200, 400, 800, 1600, 500, 1000
3-Phase : 400, 500, 1000, 2000

Performance of rotation smoothing:

⊗ less than 400 ⊙ more than 400

Behavior of resonance

The motor resonance can be reduced by increasing the steps/revolution. Following table will show the effect under the condition the resonance at full step will be 100%

steps/rev.:	behavior of resonance
200	100%
400	29%
800	8%

2 Phase Motor current setting:

The motor current is set with the HEX switch. In the picture „adjustment/display“ on side 2 you can see the motor current according to the position of the HEX switch. The value represents the amplitude of the sinusoidal phase current. The total motor current is the sum $I_{\text{motor}} = \sqrt{(I_a^2 \sin^2() + I_b^2 \cos^2())}$.

In general only as much current should be set as actually is required for the application. Too high motor currents results in unnecessary losses in motor and drive.

At higher pulse rates the motor current reduces because of the motor inductance. (see diagrams from manufactures)

3 Phase Motor current setting:

The motor current is set with the HEX switch. In the picture „adjustment/display“ on side 2 you can see the motor current according to the position of the HEX switch. The motor torque results from the sum of the 120° shifted currents of phases U, V and W.

In general only as much current should be set as actually is required for the application. Too high motor currents results in unnecessary losses in motor and drive.

At higher pulse rates the motor current reduces because of the motor inductance. (see diagrams from manufactures)

Automatic current reduction

In operating modes with pauses between movements it is useful to activate the current reduction. The motor current is reduced to approx. 60% of the set motor current. The losses in motor and drive are reduced as could be seen in following table:

current reduction	0%	to	60%
losses	100%		36%
motor torque	100%		60%

! Current reduction reduces holding torque. Assure the resulting holding torque is acceptable for your application.

The current reduction is activated, if the pulse input is inactive for more then approx. 100ms.

The current reduction can be blocked if the pulse input remains in a static active level.

With the next pulse, the current reduction is disabled immediately. The time to full motor current depends on motor type, motor voltage and pulse width(if < 15µs)

the current reduction must be activated at motor currents over 7,5A

Temperature monitoring

The fan automatic (optional) is switched on if the heat sink temperature exceeds approx. 60°C. This should be interpreted as an over temperature warning. The condition is indicated with the LED „over temp.“. The power drive is disabled, if the heat sink temperature exceeds 70° Celsius.

Motor currents grater than 5A makes an additional cooling necessary.

Power supply

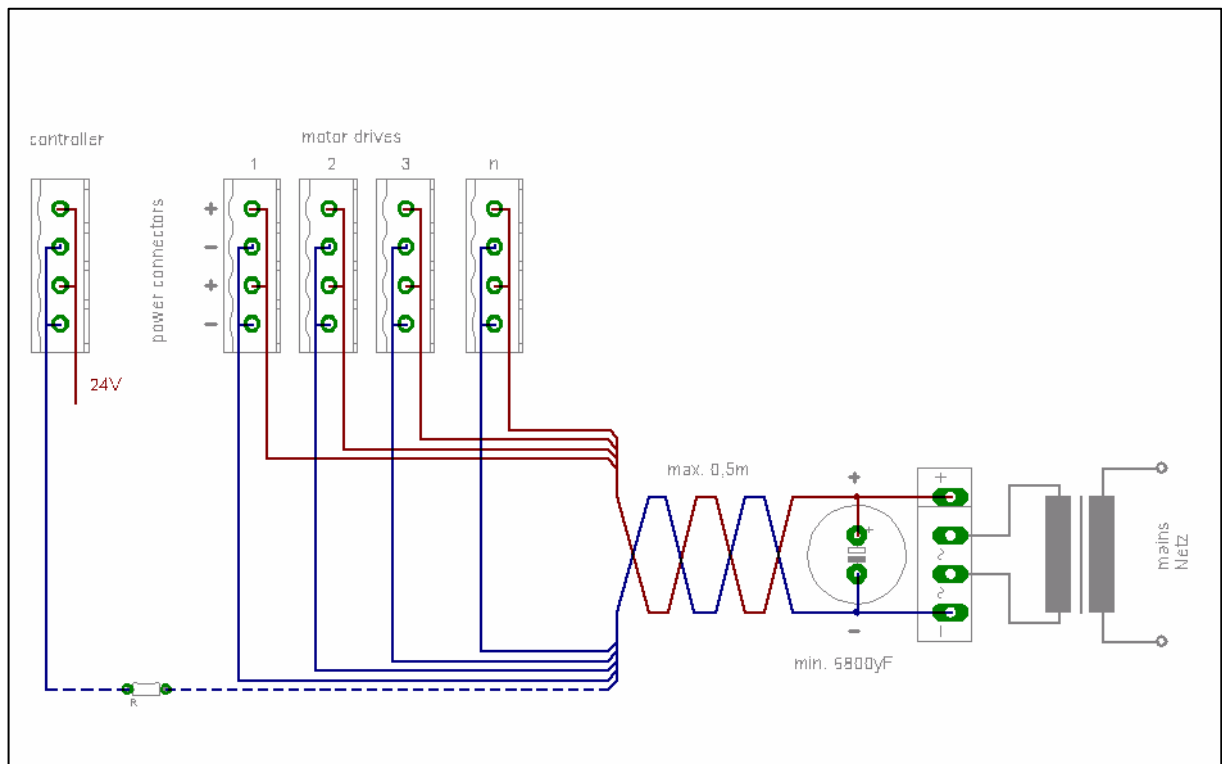

To reduce fault influences it is highly recommended to have separated power lines for each power drive. To avoid static charges when controller and power drive operates with different power supplies, it is a good praxis to insert a resistor of approx. 100kOhm between controller and power drive.

Power supply

It must be guaranteed that the power supply have an capacitor of at least 6800yF. An active internal ballast circuit eliminates short over voltages caused by generator operation occurring during fast deceleration. This condition is indicated with the over voltage LED that only be lit for a short period of time during this condition.

Too high motor voltages may damage the power drive.

Never connect live supply voltage wires to the terminals, because the sudden charge current of the internal electrolytic capacitors can destroy the internal fuses

! Check for correct polarity

Timing

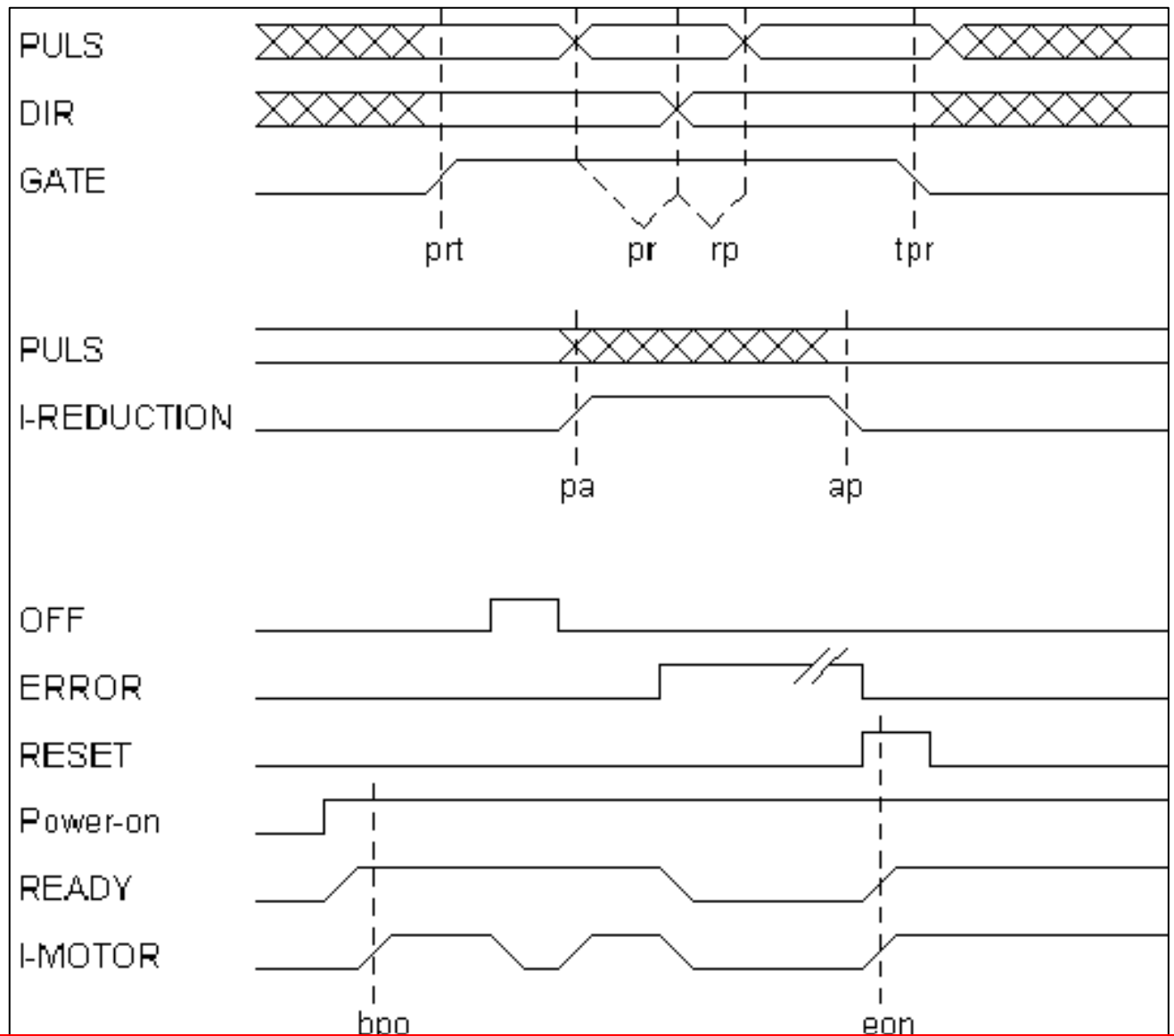

! Pulse slope	max	2μs
! Pulse width:	min	5μs
! ERROR:	OFF-Signal in fault condition	

prt:	> 5 μ s	gate active after pulse/direction
tpr:	> 10ms	pulse/direction active after gate
pr:	> 5 μ s	pulse before direction
rp:	> 5 μ s	pulse after direction
pa:	< 150ms	I-reduction active after pulse
ap:	< 0,5ms	I-reduction deactive after pulse
bpo:	< 1s	ready after power-on
eon:	< 100ms	ready after reset

Dimensions

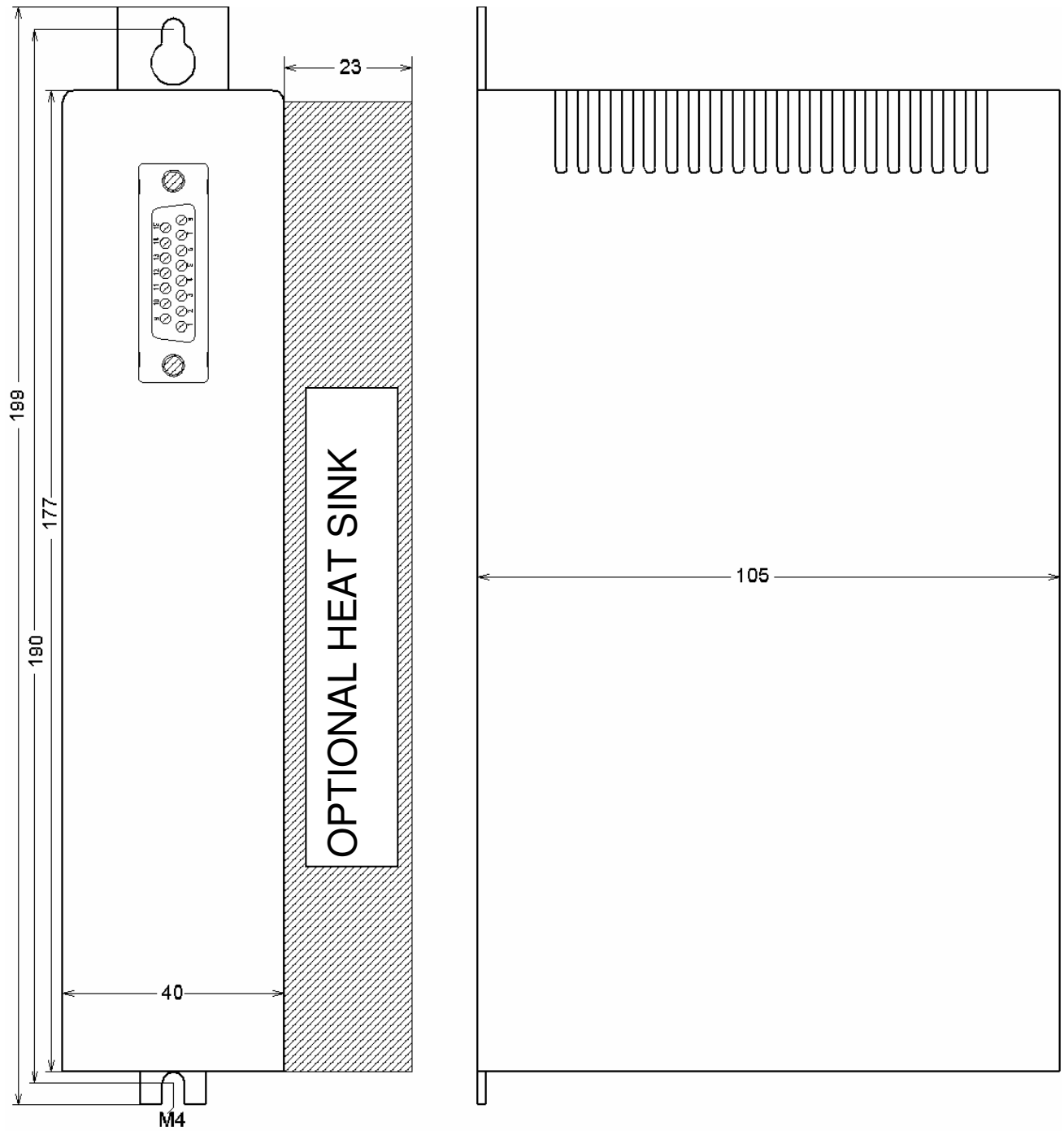

Technical specifications:

Power drive supply:	285, 2810, 2135, 21310
Absolute max. voltage:	85, 85, 135, 135V
Minimum voltage:	24, 24, 80, 80V
recommended voltage Un:	80, 80, 130, 130V
Voltage ripple:	< 2,0Vss
Input peak current at power on:	< 4,0A
Fusing:	5,0Amt
Power supply charge capacitor:	>6800µF
Power supply cable cross section:	0,75mm ²
Distance to power supply capacitor	<0,3m

Motor connection:

Cable cross section:	<4A	>0,75mm ²
	>4A	>1,00mm ²
Cable length:		<10m

Signal input interface: (24V signal interface)

Pulse, Direction, Gate, Off, Fast

Input type:	Opto coupler
Input voltage: low:	< 1V(6V)
high	>3,5V(15V)
nominal	5V(24V)
max.	6V(28V)
Input resistance	ca.220(2k2)Ohm

Signal output interface:

Ready, Zerophase

Output type:	Opto coupler
Switching voltage:	<30V
Inner resistance:	<15 Ohm
Switching current:	< 50 mA
Load:	only ohmic

Temperature monitoring:

Automatic fan control active :	->ca. 60°
Switch off:	> ca. 70 °

Current reduction, active at frequencies lower than

Pulse width:	5ys	10ys	50ys	100ys
Current red.:	50Hz	30Hz	20Hz	15Hz

Ambient conditions:

Temperature:	40° max
UL94V-1 all components	
IP20	

Electromagnetic compatibility

Radio interference:	EN55011B
Static discharge:	4kV
Burst:	IEC-Level 4 / 2,5kHz

Trouble shooting:

Motor has no holding torque

- The motor voltage is below the minimum value
- Signal inputs "reset" or "off" are active
- The over temperature monitoring is still active
- A non-valid step resolution is selected

Motor has holding torque, but doesn't execute steps

- The "GATE" input is active
- The pulse level is too low (24V interface)

"TEMP"-LED is on immediately after power on

- The heat sink couldn't cool down sufficiently

"Over curr."-LED is on immediately after power on

- The power drive is damaged
- The motor winding has a short cut

Sudden "crackling" noises in the motor

- Motor is operated at the minimum voltage limit
- The motor connection is bad

The motor doesn't reach the set speed but starts

- The motor voltage is too low for the required speed
- The motor current was set too low
- The acceleration ramp was set too high
- Motor wires are too long or too small cross section
- Power supply is not powerful enough

The motor "loses" steps and drifts

- The amplitudes of the control signals are too low
- Signal cable noise is too high (shielded cables?)
- The wiring concept is not optimal (system ground)
- The mechanical shaft coupling has play

Motor vibrates at pulse frequency and doesn't start

- Start/Stop-frequency too high
- Motor windings are connected wrong or broken cable
- The motor current is set too low

The automatic current reduction doesn't work

- The pulse input remains active after the last
- The current reduction is not enabled

The over voltage LED is often/permanently lit

- The supply voltage is too high

The motor is hot

Up to 85 ° Celsius should be no problem

Step angle too different

- Motor inductance is too high
- Motor current too less

GENERAL INSTALLATION REQUIREMENTS

The device housing¹ must be grounded separately. In most cases a wing nut on the front panel or another grounding connection is available. Each component must be grounded with a separate grounding wire at a central "grounding point". This is usually the machine bed or a grounding rail inside the electrical cabinet.

Before installation and setup make sure that the required drive power is sufficient for your application and that the maximum values are not exceeded.

Mounting orientation is vertical, make sure air intake¹ and cooling slots are not blocked.

Only shielded motor cable must be installed. For identical potential between motor flange and power drive (short distance) the shield is grounded on both ends. Otherwise it is recommended to ground only the device end and that the shield on the motor end is ground connected galvanically isolated via a capacitor.

In general the ground potential difference must be in the range of only a couple mV.

For symmetrical motor cables such as with 2 phase steppers twisted pair wires are recommended per circuit.

Signal cables must also be shielded. Twisted pair wires are recommended per circuit.

The ground potential common point should be located directly at the housing or the mounting point of the power drive.

Signal cable and motor cable must be separated. Long parallel cable installation must be avoided. Cable crossings (if necessary) should be installed vertically.

Check all device settings for validity..

SAFETY AND PROTECTION REQUIREMENTS

The installation of the device must only be conducted by an educated, trained and experienced expert (electro). The local guidelines for safety, installation of electrical and mechanical systems and EMI must be observed.

Unintended operation and faulty installation of the device can lead to personal injury (incl. the possibility of death)

and the device as well as other external components can be damaged or an excessive pollution of the environment can occur.

Operation is only permitted with the mounted housing². Because of eventually present high voltage the device must not be opened (also not after a long period of idle time). Make sure children have no direct access to the device.

No technical modifications of the device are permitted.

The device housing³ must be grounded separately. In most cases a wing nut on the front panel or another grounding connection is available. The device must be grounded prior to the installation.

Under no circumstances live of functional connectors must be removed or connected. All installations must be conducted in the powerless de-energized state.

Device operation in damp, humid environment or with present spray water is not permitted.

¹ if available

² not with open frame (only PCBs)

³ if available